

Model #: ATN240

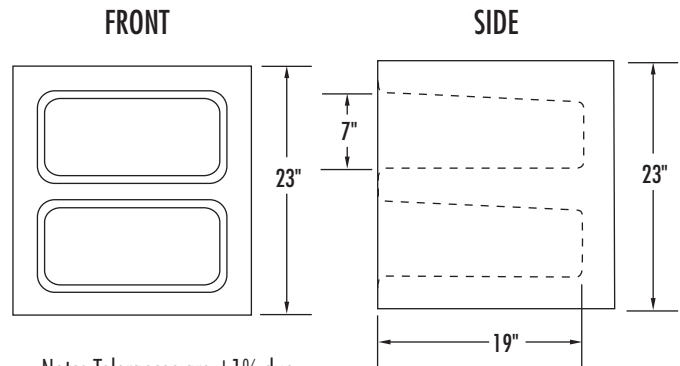
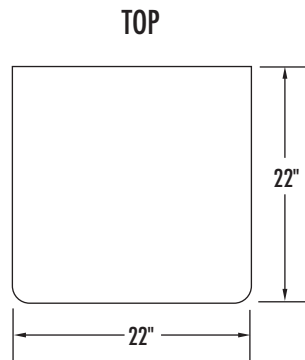

Note: Tolerances are $\pm 1\%$ due to manufacturing process.

Overview

Floor mounted nightstand. Engineered for intensive use environments and institutional durability. Proven suitable for continuous daily use in a healthcare or correctional environment. Impact resistant.

Fabrication:

Slightly textured maintenance free surface allows for easy cleaning.

Material

Rotationally molded, specially formulated, fire-retardant, high-impact polyethylene with ultraviolet light stabilizers (to reduce fading.) Chemically resistant to blood, vinegar, urine, feces, salt solution and chlorine solution. Unit is filled with rigid polyurethane foam for increased durability and sound absorption.

Flammability:

Certified to pass the following flammability standards:

- State of California, Technical Bulletin No. 133, Flammability Test Procedure for Seating Furniture for Use in Public Occupancies.
- UL1056 Fire Test of Upholstered Furniture
- ASTM E1537 Test Method for Fire Testing of Real Scale Upholstered Furniture Items
- NFPA 261 Cigarette Ignition Resistance of Upholstered Furniture

Color:

Mulberry, Sawgrass, Pine Cone, Golden Wheat, Lagoon, River Rock.

Weight:

28 lbs.

Assembly:

None required.

Installation:

Anchors required for permanently attaching to floor. Anchors not supplied by Norix.

Warranty:

5 year limited replacement warranty.

Maintenance:

Easily cleaned with a damp cloth and a mild soap solution.

Filing System:

12600 Institutional Furniture
11197 Correctional Furniture