

Model #: ATN310

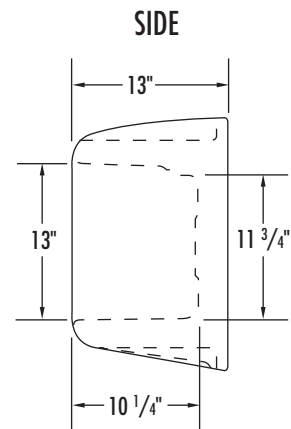
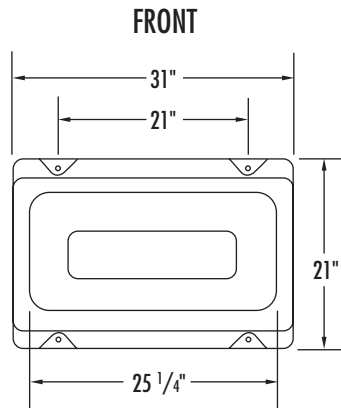

Note: Tolerances are  $\pm 1\%$  due to manufacturing process.

**Overview**

Wall-mounted, compartment storage shelf. Engineered for intensive use environments and institutional durability. Proven suitable for continuous daily use in a healthcare or correctional environment. Impact resistant. Rounded corners and tapered top for safety. Designed to be mounted to solid concrete walls.

**Fabrication:**

Slightly textured maintenance free surface allows for easy cleaning.

**Material**

Rotationally molded, specially formulated, fire-retardant, high impact polyethylene with ultraviolet light stabilizers (to reduce fading.) Unit is filled with rigid polyurethane foam for increased durability and sound absorption.

**Flammability:**

Certified to pass the following flammability standards:

- State of California, Technical Bulletin No. 133, Flammability Test Procedure for Seating Furniture for Use in Public Occupancies.
- UL1056 Fire Test of Upholstered Furniture
- ASTM E1537 Test Method for Fire Testing of Real Scale Upholstered Furniture Items
- NFPA 261 Cigarette Ignition Resistance of Upholstered Furniture

**Color:**

Mulberry, Sawgrass, Pine Cone, Golden Wheat, Lagoon, River Rock.

**Weight:**

20 lbs.

**Assembly:**

None required.

**Installation:**

Anchors required for permanently attaching to solid wall. Anchors not supplied by Norix. Groove along mounting surface for caulk application (caulk not supplied by Norix).

**Warranty:**

5 year limited replacement warranty.

**Maintenance:**

Easily cleaned with a damp cloth and a mild soap solution.

**Filing System:**

12600 Institutional Furniture  
11197 Correctional Furniture