

Model #: IFP-100

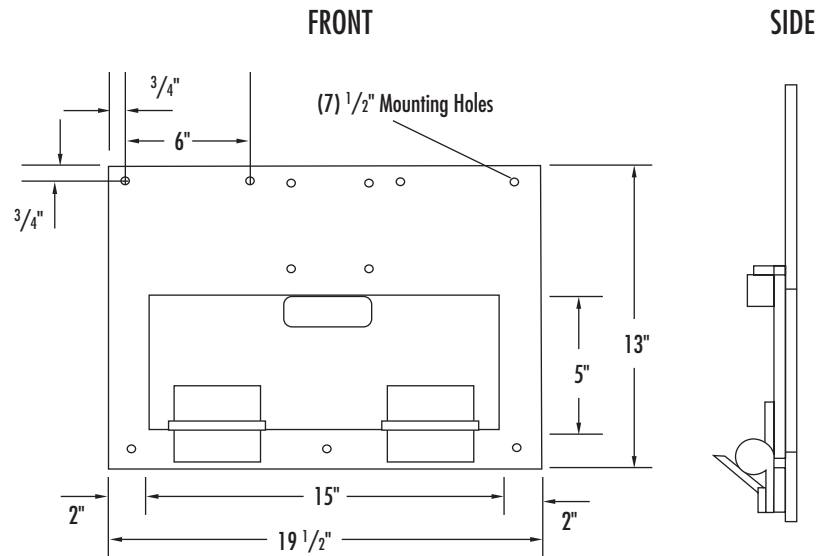

Overview

Door opens 90° to provide a pass and shelf for food trays.

Fabrication & Material:

Fabricated 7 gauge frame with 10 gauge flat door attached with 10 gauge steel butt hinges. Manufactured to accept a paracentric high security lock.

Finish:

Primed.

Weight:

29 lbs.

Assembly:

Shipped assembled.

Installation:

Frame has seven (7) 1/2" dia. mounting holes for 1/4"-20 security screws to attach to standard 5" x 15" opening. Hardware not supplied by Norix.

Warranty:

1 year limited replacement warranty.

Maintenance:

Standard household or commercial cleaners.

Filing System:

11190 Detention Furnishings