

norix®

FURNITURE

Extraordinary by Design™

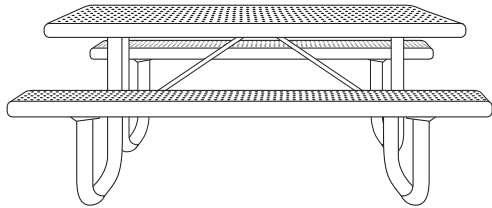

Model #: H000-06 (6' Table)
H000-08 (8' Table)
H010-08 (8' ADA Table)

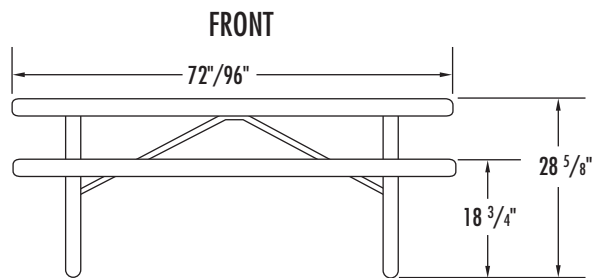

Overview

All Hilltop Series products have been outdoor tested in the extremes of icy northern winters to the intense heat of the southwest to the salt air of the oceans. The machine perforated 14-gauge steel tops and seats have a smooth UV-stabilized vinyl coating bonded to the steel that is impervious to both bad weather and rough use. Water drains through and the coating keeps the seat and tops from corroding and getting too hot in the sun.

Fabrication:

Support Frame: Steel tubing with welded flanges for mounting the seats and top. The welded assembly is primed and dipped in U.V. stabilized PVC. The frame is totally sealed from the elements with a colorful weatherproof coating.

Braces: Formed flat steel finished with the same PVC coating as the frame.

Seats and Top: Formed perforated steel sheet that drains liquids and allows see through visibility (security). Each part has an angle iron support welded to the bottom for attachment to the frame. Parts are then primed and dipped in U.V. stabilized PVC.

Material:

Support Frame: 2 3/8" O.D. x 12 ga. steel tube.

Braces: 12 ga. formed steel.

Top and Seats: 14 ga. perforated steel sheet. Perforated with 3/8" dia. holes on 3/4" centers.

Finish: U.V. stabilized PVC.

Hilltop Rectangle Table

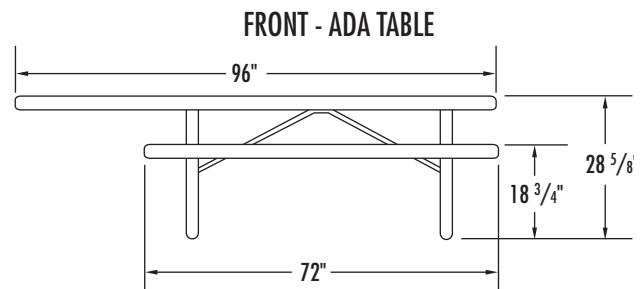
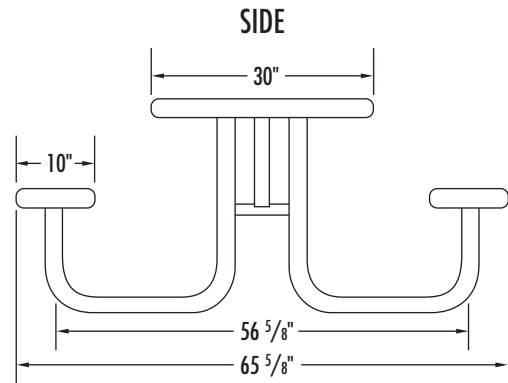

Flammability:

Certified to pass the following flammability standards:

- State of California, Technical Bulletin No. 133, Flammability Test Procedure for Seating Furniture for Use in Public Occupancies.

Color:

Taupe, Red, Blue, Dark Green, Brown.

Weight:

H000-06 (6' Table): 208 lbs.

H000-08 (8' Table): 251 lbs.

H010-08 (8' ADA Table): 229 lbs.

Assembly:

Ships K.D. Some assembly required.

Installation:

None required.

Warranty:

5 year limited replacement warranty.

Maintenance:

Easily cleaned with a damp cloth and a mild soap solution.

Filing System:

12600 Institutional Furniture

11197 Correctional Furniture

H2

Norix Group, Inc. • 1000 Atlantic Drive, West Chicago, IL 60185-5101
Phone: 800-234-4900 • 630-231-1331 • Fax: 630-231-4343 • Email: furniture@norix.com • www.norix.com
Specifications subject to change without notice. ©2012 Norix Group, Inc. All Rights Reserved. Printed in U.S.A. 1/12

norix®