

Model #: C110

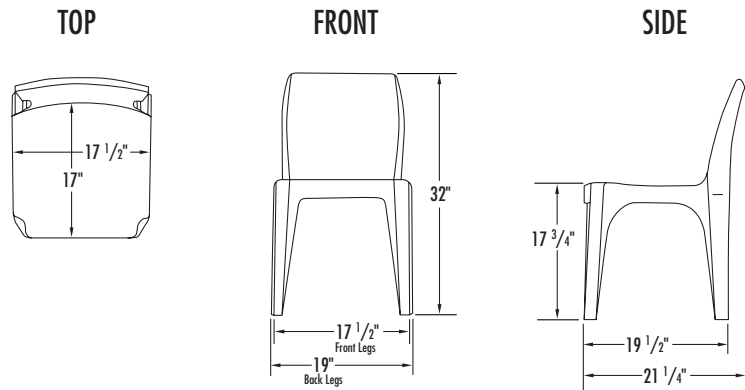

Overview

Multi-use stackable armless chair. Engineered and proven suitable for continuous daily use in an institutional environment. (Note: For safety reasons, chairs with open backs or arms, patio style, or residential quality chairs should not be used for this requirement). Compatible style, color, construction, material, functionality and durability with arm chairs, lounge chairs and tables provided by Norix.

Fabrication:

One-piece injection molded, without steel or wood components. 1 1/2" deep "X" rib on the underside of the seat, connecting legs diagonally for superior strength. Honeycomb reinforcing rib cells.

Material:

High impact grade copolymer polypropylene with FRPP5 Fire Retardant. Chemically resistant to acetone, alcohol, blood, vinegar, urine, feces, salt solution and chlorine solution.

Flammability Test Standards:

Certified to pass the following flammability standards:

- State of California, Technical Bulletin No. 133, Flammability Test Procedure for Seating Furniture for Use in Public Occupancies.
- Federal Aviation Administration Test 25.853 A & B, Appendix F, Part 1, 60 second gas burner ignition, material self-extinguishing & 12 second gas burner ignition, material self-extinguishing. (Note: Flammability tests reflect standardized laboratory test procedures and may not reflect results in actual fire conditions).

Performance Test Standards:

- ANSI/BIFMA X5.1 2002 General Purpose Office Chairs.
- ISO 9001-1987: Quality certified manufacturer.
- ASTM F1561-94, Parts A & B: Standard Performance Test for Plastic Chairs.
- Furniture Industry Research Association: Grade 5 - Severe Contract Applications, 200,000+ cycles.

Color:

Mulberry, Sawgrass, Pine Cone, Golden Wheat, Lagoon, River Rock, Autumn Leaf, Raven.

Stacking:

15 chairs in 83".

Weight:

7.1 lbs.

Options:

3 wheel dolly.

Assembly:

None required.

Installation:

None required.

Warranty:

5 year limited replacement warranty.

Maintenance:

Easily cleaned with a damp cloth and a mild soap solution.

Filing System:

12600 Institutional Furniture

11197 Correctional Furniture