

Integra Stacking Lounge Chair

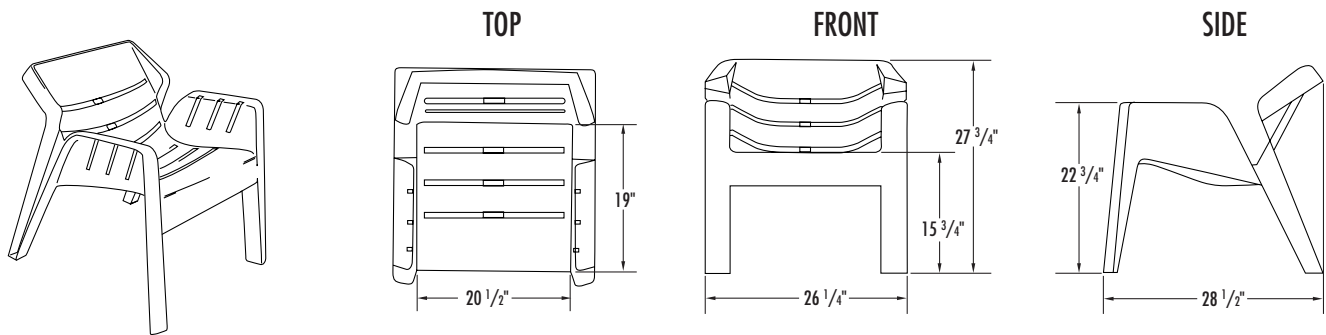

Model #: C130

Overview

Stackable lounge chair. Suitable for continuous daily use in an institutional environment. (Note: For safety reasons, chairs with open backs or arms, patio style, or residential quality chairs, should not be used for this requirement). Compatible style, construction, material, functionality and durability with arm and armless chairs, provided by Norix.

Fabrication:

One-piece injection molded, without steel or wood components.

Material:

High grade copolymer polypropylene with FRPP5 Fire Retardant. Chemically resistant to acetone, alcohol, blood, vinegar, urine, feces, salt solution and chlorine solution.

Flammability Test Standards:

Certified to pass the following flammability standard:

- State of California, Technical Bulletin No. 133, Flammability Test Procedure for Seating Furniture for Use in Public Occupancies.

Performance Test Standards:

- ISO 9001-1987: Quality certified manufacturer.
- Furniture Industry Research Association: Grade 5 - Severe Contract Applications, 200,000+ cycles.

Color:

Fog Grey.

Stacking:

12 chairs in 82".

Weight:

13 lbs.

Assembly:

None required.

Installation:

None required.

Warranty:

5 year limited replacement warranty.

Maintenance:

Easily cleaned with a damp cloth and a mild soap solution.

Filing System:

12600 Institutional Furniture
11197 Correctional Furniture