

Model #: LBWOS1 (1 Unit)
LBWOS2 (2 Units)
LBWOS3 (3 Units)

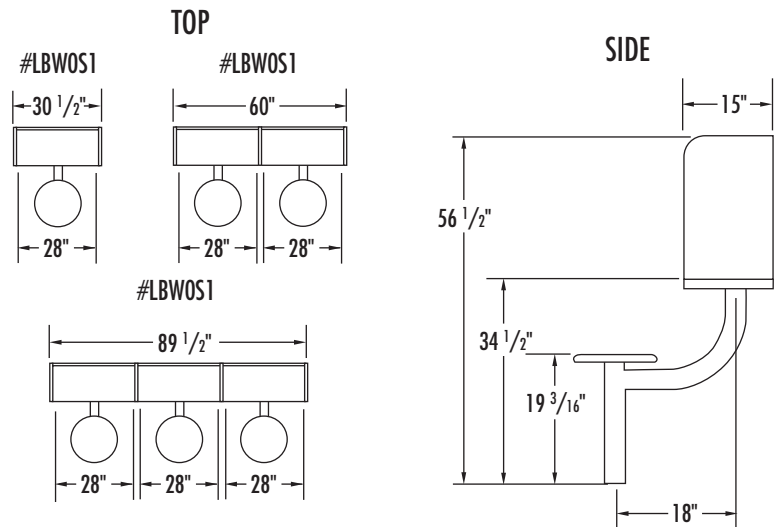

Overview

Wall-mount stations with attached seating designed for surface mounting of video and voice communications equipment (not included). Engineered for institutional durability. Suitable for continuous daily use in a correctional or institutional environment for inmates and visitors.

Fabrication:

Bolt together with tamper-resistant mechanical fasteners (supplied).
Wall-mount.

Sides & Writing Surface: High-pressure laminate bonded to 45 lb. density particle board.

T-mold vinyl edges are glued around circumference for tamper-resistance and security. Panels connect with internal barrel bolts.

Legs and Seat Support: 10" radius curved portions of the legs support the top and for additional strength are fully welded to the vertical tubes that support the seats. The tops of the curved tubes and the tops of the seat support tubes are fully welded to 6" x 6" x 1/4" thick steel plates. The bottoms of the seat tubes are fully enclosed to conceal floor-mounting anchors.

Material:

Sides & Writing Surface: Heavy-duty laminate on 45 lb. density particle board.

Face Plate: 14 gauge black powder coated steel.

Legs: 3" diameter 14 gauge steel finished with black powder coat paint.

Seats: Option 1: Super Slammer Stone – 13" diameter high-density color impregnated compression molded composite that is highly scratch and stain resistant.

Option 2: Stainless Steel – 14 gauge, type 304. One-piece 12" diameter with 1 1/2" drop edge. #4 finish.

Color:

Sides & Writing Surface: Wilsonart Ebony Star 4552-90 textured Crystal finish.

Face Plate: Black powder coat.

Legs and Vinyl Edge: Black.

Seats: Mulberry, Sawgrass, Pine Cone, Golden Wheat, Lagoon, River Rock, Autumn Leaf, Raven, Stainless Steel.

Weight:

Varies by model. Contact factory.

Assembly:

Assembly required. Refer to manufacturers instructions.

Installation:

Attach wall-mount unit to wall using furnished mounting brackets.

Anchors or bolts not included. Anchor legs to floor using provided concealed concrete expansion anchors.

Warranty:

5 year limited replacement warranty.

Maintenance:

Easily cleaned with a damp cloth and a mild soap solution.

Filing System:

12600 Institutional Furniture

11197 Correctional Furniture