

Model #: B510-300

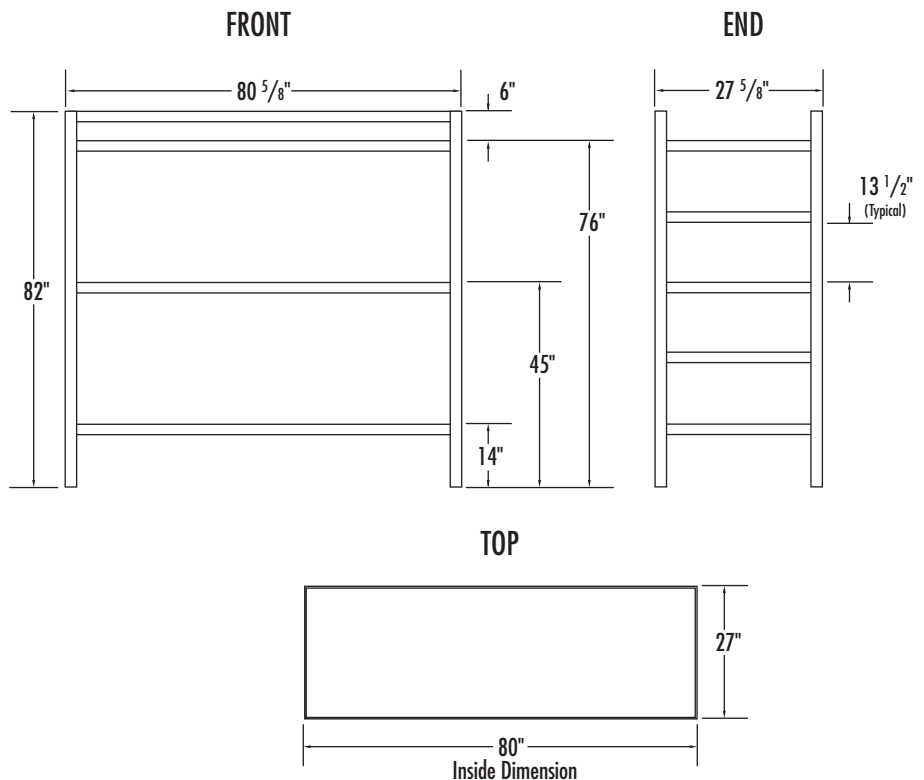

Overview

Extra heavy gauge bunks intended for use in cells and sleeping areas in correctional environments. Fully welded.

Fabrication:

Universal formed steel pan. Bunks have a baked on factory applied powder coat finish. Built in safety rails and ladder.

Material:

Pan: 12 gauge steel. Standard size is 27" x 80"

Legs: 2" x 2" x 3/16" standard angle with bolt down tabs.

Ladder Rung & Safety Rails: 2" x 2" x 3/16" standard angle.

Color:

Grey.

Weight:

380 lbs.

Options:

Rail sets and locking plates for property boxes.

10 gauge steel pan.

Prime coat finish.

Towel hooks.

Assembly:

None required.

Installation:

Weld or bolt unit to floor.

Floor mounting hardware not included.

Warranty:

1 year limited replacement warranty.

Maintenance:

Easily cleaned with a damp cloth and mild soap solution.

Filing System:

12600 Institutional Furniture

11197 Correctional Furniture