

Leg Style Table

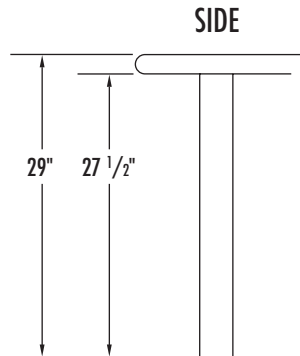

TOP

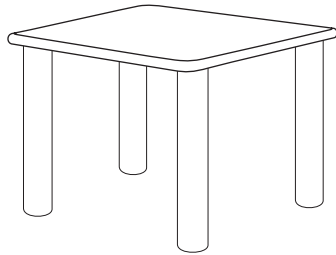
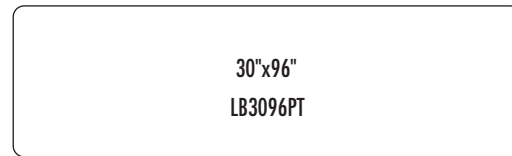
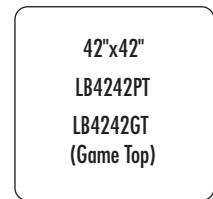
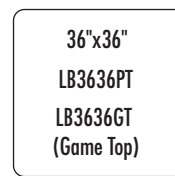
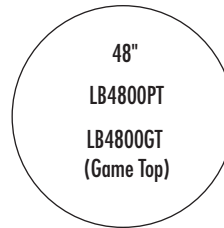

Overview

Heavy duty leg style tables built for stability. Engineered and suitable for continuous daily use in an institutional environment.

Fabrication:

Legs: Steel tubing welded to steel plate for attaching top. Bottom of leg sealed by means of a fully welded inset threaded to accommodate a non-removable adjustable leveling glide.

Top: Permanently bonded to a core of 45 lb. density M3 grade particle board with permanently embedded T-nuts for securing top to base with a metal-to-metal connection.

Material:

Legs: 4" diameter, 14 gauge wall thickness steel tubing welded to a 6" x 6" x 1/4" steel plate.

Laminate Top: Decorative high pressure laminate sealed with a specially formulated highly durable Slammer Stone edge. Edge is radiused for safety and pressure fused to the top rendering it permanently non-removable and highly sanitary. 1 1/2" thick edge profile.

NorStone™ Top: Specialty formulated composite, compression molded to create a seamless, one-piece top and edge surface for superior impact resistance and durability. 22% of the material is soy based resin, a renewable raw material with 35% less harmful CO2 contribution and 3,800 BTUs p/pound of resin less energy than standard petro chemical based equivalents. NorStone table tops can be used toward LEEDs Material & Resources' Rapidly Renewable Materials category, Bio-Preferred and Greenguard.

Color:

Base: Black textured powder coat.

Laminate Top: Wilsonart® Titanium Evolve #4810-60 with black Slammer Stone edge.

NorStone™ Top: Carbon or Quarry.

Weight:

Varies on model. Contact Manufacturer.

Options:

Bolt-down configuration.

Game tops (GT): Checkerboard available on NorStone™ tops.

Checkerboard / backgammon / solitaire available on laminate tops (square and round tables only).

1 1/4" laminate top with black vinyl T-mold edge.

2 1/2" diameter legs.

Assembly:

Refer to manufacturers instructions for securing top to base.

Installation:

None required.

Warranty:

5 year limited replacement warranty.

Maintenance:

Easily cleaned with a damp cloth and mild soap solution.

Filing System:

12600 Institutional Furniture

11197 Correctional Furniture