

**Overview**

Dayroom/Dining table and seat combination. Choice of 3 tops with 4, 6, or 8 seats. Engineered and suitable for continuous daily use in an institutional environment.

**Fabrication:**

Base: The curved member that supports the top has a 10" radius bend to facilitate easy cleaning beneath the table. This curved piece is fully welded to a vertical steel tube that supports the seat. The top of the curved tubes and top of the seat tubes have fully welded 6" x 6" x 1/4" thick steel mounting plates for installing top and seats. Bottom of seat tube has a fully welded mounting plate inset. For free standing applications, the inset is threaded to accommodate a non-removable, skid resistant, adjustable glide with a 1/2" diameter stem. For bolt-down application, the inset has a hole for the fully enclosed tamper-resistant bolt-down system.

Top: 45 lb. density particle board, with permanently embedded T-nuts for securing the top to the base.

**Material:**

Base: 3" diameter, 14 gauge steel tubing.

Laminate Top: Decorative high pressure laminate sealed with a specially formulated highly durable Slammer Stone edge. Edges are radiused for safety and pressure fused to the top rendering it permanently non-removable and highly sanitary. 1 1/2" thick edge profile.

Nu-Stone<sup>®</sup> Top: Specially formulated fiberglass filled polyester composite, compression molded under 2,000 p.s.i. pressure to create a seamless, one-piece top and edge surface for superior impact resistance and durability.

1 1/2" thick edge profile (Available on 42" diameter only).

Stainless Steel Inlay Top: Durable type 304 stainless steel surface sealed with a specially formulated highly durable Slammer Stone edge. Edges are radiused for safety and pressure fused to the top rendering it permanently non-removable and highly sanitary. 1 1/4" thick edge profile.

Super Slammer Stone<sup>®</sup> Seats: 13" diameter high density color impregnated compression molded composite that is highly scratch and stain resistant. Four molded-in threaded inserts for superior metal-to-metal connection.

**Performance Test Standards:**

Static load to 3000 lbs.

**Color:**

Base: Black

Laminate Top: Wilsonart<sup>®</sup> Titanium Evolve #4810-60 with black Slammer Stone edge.

NuStone<sup>®</sup> Top: GraniteStone or PebbleStone (see color chart).

Stainless Steel Inlay Top: #4 finish.

Seats: Buff, Fog Grey, Blue Grey, Plum, Teal, Slate Blue, Mahogany, Black.

**Options:**

Seats: 12" diameter stainless steel #4 finish.

Legs: Clear PVC leg protectors; Glides.

Game tops (GT): Checkerboard available on Nu-Stone<sup>®</sup> and Stainless Steel Inlay tops. Checkerboard / backgammon / solitaire available on laminate tops (except on 30 x 72).

**Assembly:**

Secure base to top. Attach seats.

**Installation:**

Fasten to the floor. No installation required on free standing models.

Concealed concrete expansion anchors included with bolt to the floor option.

**Warranty:**

5 year limited replacement warranty.

**Maintenance:**

Easily cleaned with a damp cloth and a mild soap solution.

**Filing System:**

12600 Institutional Furniture

11197 Correctional Furniture

Continued on back.

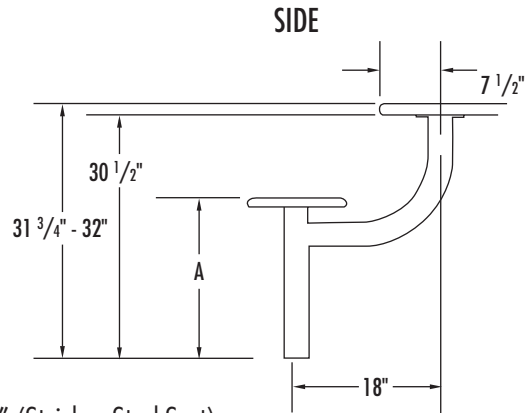
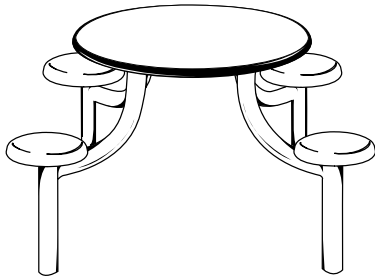

A: 19 1/4" (Stainless Steel Seat)  
19 3/4" (Super Slammer Stone Seat)

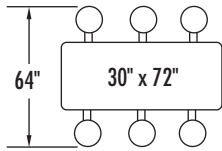

Model #: MX3072-6

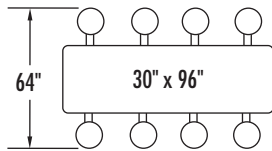

Model #: MX3096-8

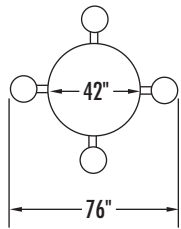

Model #: MX4200-4

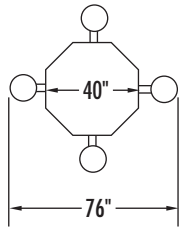

Model #: MX4040-4

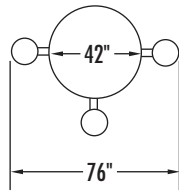

Model #: MX4200 ADA

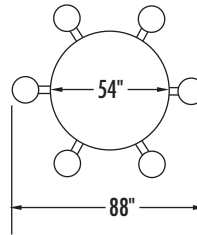

Model #: MX5400-6

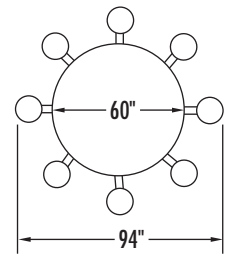

Model #: MX6000-8