

Max-Master Wall Mount Table

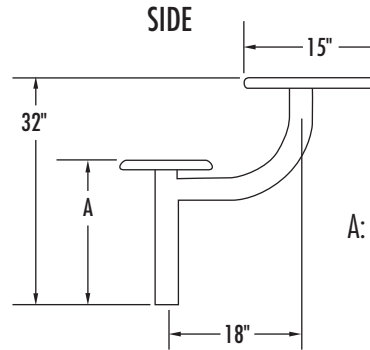

A: 19 3/4" (Super Slammer Stone Seat)
19 1/4" (Stainless Steel Seat)

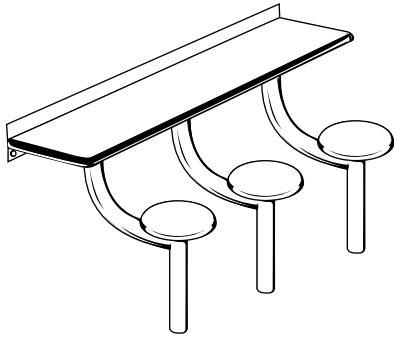
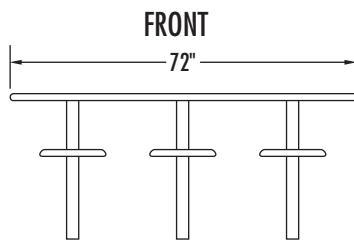

Model #: MX1572-3

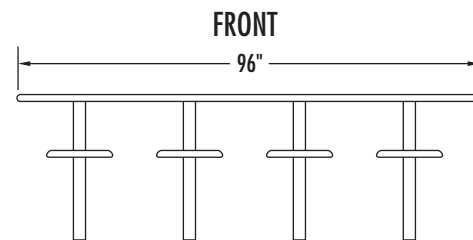

Model #: MX1596-4

Overview

Wall mounted one-piece table/seating units. Engineered and suitable for continuous daily use in an institutional or correctional environment.

Fabrication:

Leg/Base: The curved member that supports the top has a 10" radius bend to facilitate easy cleaning beneath the table. This curved piece is fully welded to a vertical steel tube that supports the seat. The top of the curved tubes and top of the seat tubes have fully welded 6" x 6" x 1/4" thick steel mounting plates for mounting top and seats. Bottom of seat tube has a fully welded mounting plate inset. The inset has a hole for the fully enclosed tamper-resistant bolt-down system.

Top: 45 lb. particle board, with permanently embedded T-nuts for securing the top to the base.

Material:

Base: 3" diameter, 14 gauge steel tubing.

Laminate Top: Decorative high pressure laminate sealed with a specially formulated highly durable Slammer Stone edge. 1 1/2" thick edge profile. Edges are radiused for safety and pressure fused to the top rendering it permanently non-removable and highly sanitary.

Super Slammer Stone® Seats: 13" diameter high density color impregnated compression molded composite that is highly scratch and stain resistant. Four molded-in threaded inserts for superior metal-to-metal connection.

Color:

Leg/Base: Black; Top: Wilsonart® Titanium Evolve #4810-60 with black Slammer Stone edge

Seats: Buff, Fog Grey, Blue Grey, Plum, Teal, Slate Blue, Mahogany, Black.

Options:

Seats: 12" diameter stainless steel #4 finish.

Assembly:

Secure leg and wall bracket to underside of top. Attach seat.

Installation:

Fasten to floor and wall. Wall mounting hardware not included.

Warranty:

5 year limited replacement warranty.

Maintenance:

Easily cleaned with a damp cloth and a mild soap solution.

Filing System:

12600 Institutional Furniture
11197 Correctional Furniture