

Model #: IPP-100

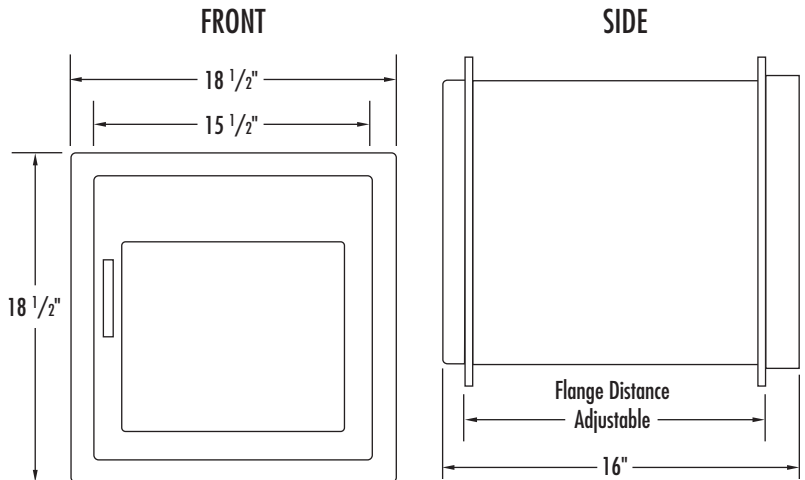

Model #: IPP-150 (Package Pass with Vision Door)

Overview

Sally port style security with interconnected doors keeping one closed when the other is open. Level I bullet resistant.

Fabrication & Material:

Cut, notched, formed and welded 7 gauge steel frame with 10 gauge steel doors and 16 gauge piano hinge.

Finish:

Primer painted housing. Stainless steel door. Optional polycarbonate door available.

Weight:

Package Pass: 92 lbs.

Package Pass with Vision Door: 70 lbs.

Options:

Level I or III bullet resistant polycarbonate.

Assembly:

Compartment shipped assembled. Flange shipped loose for field installation.

Installation:

Outer frame is field welded to box after installation.

Wall opening size: 15 1/2" x 15 1/2".

Warranty:

1 year limited replacement warranty.

Maintenance:

Standard household or commercial cleaners.

Filing System:

11190 Detention Furnishings