

Model #: IPH-200

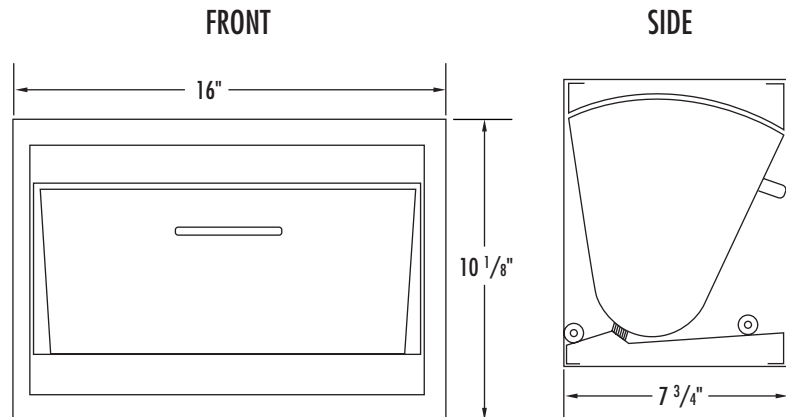

**Overview**

Stainless steel hopper features simple tilt mechanism that latches on one side. Level 1 bullet resistant.

**Fabrication & Material:**

Cut, formed and welded stainless steel assembled to fit countertop, window or wall openings. Steel and stainless steel on exposed surfaces.

**Finish:**

#4 finish stainless steel.

**Weight:**

47 lbs.

**Assembly:**

Shipped assembled.

**Installation:**

Stainless steel mounting flange. Shipped loose. Field weld to hollow metal flange.

**Warranty:**

1 year limited replacement warranty.

**Maintenance:**

Standard household or commercial cleaners.

**Filing System:**

11190 Detention Furnishings