

Model #: RK2119

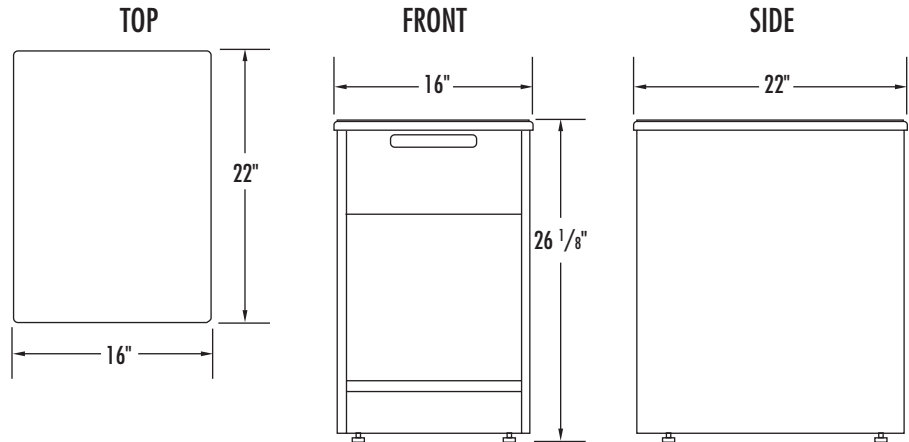

Overview

Residential room furnishing designed and engineered specifically for critical environments. The Tamarack™ Nightstand features Dura-Ply™ construction and built in safety and security features including tamper resistant fasteners and a non-removable drawer.

Fabrication & Material:

Cabinet is 3/4" plywood with natural hardwood veneer securely doweled and glued at strategic locations. High-pressure laminate top surface with rounded solid hardwood edge for enhanced wear resistance and cleanability. Sturdy 3/4" plywood back panel is securely fastened to unit for additional structural integrity. Single non-removable drawer opens 3/4 extension for added security and is supported with 75 lb. rated heavy duty drawer slides. Open lower cavity provides additional storage. Replaceable solid hardwood drawer faces include an integrated finger pull for durability. Internal cam locks restrict access and are used in conjunction with square head tamper resistant fasteners and glued dowel pins to prevent disassembly. Non-mar floor glides are standard.

Finish:

Catalyzed vinyl sealer coat plus catalyzed varnish top coat for wear resistance.

Color:

Oak, Cherry
Laminate Top: Wilsonart® Solar Oak #7816-60, Wilsonart® Wild Cherry 7054-60.

Options:

Drawer lock.

Weight:

90 lbs.

Assembly:

No assemble required.

Installation:

None required.

Warranty:

5-year limited replacement warranty for defects in materials and workmanship. Wood is a natural material subject to unique variations. Norix does not warranty the matching of color, grain or texture.

Maintenance:

Easily cleaned with normal household wood care products.

Filing System:

12600 Institutional Furniture
11197 Correctional Furniture