

Model #: C150

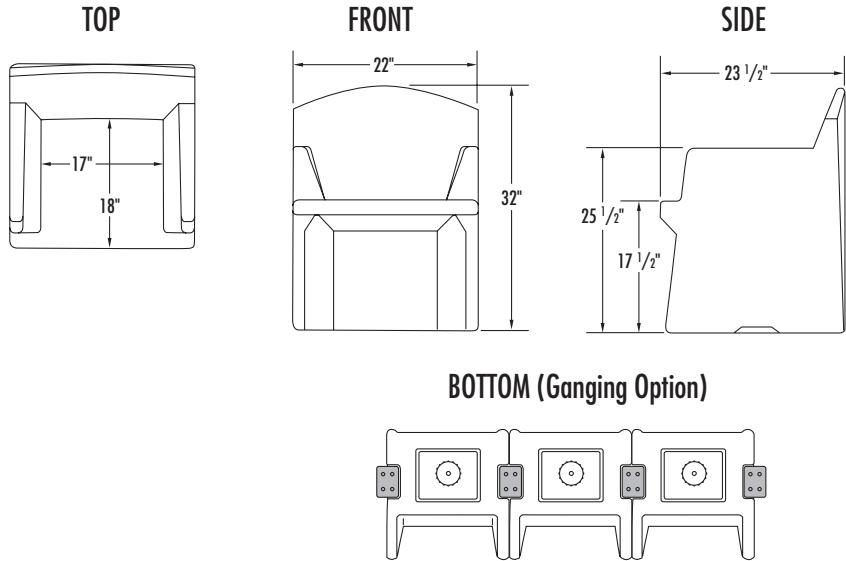

Overview

Compact multi-use chair system. Ganging and ballasting capability assures these chairs can be reconfigured as future needs require. Engineered and proven suitable for continuous daily use in an institutional environment. Ergonomically designed for comfort without the use of foam for cushioning.

Fabrication:

One-piece rotationally molded. Perimeter floor support to facilitate ease of cleaning and to prevent concealment of contraband. Molded-in steel threaded inserts for ganging side-to-side or bolt-down applications.

Material:

Specially formulated fire retardant high impact polyethylene with ultraviolet light stabilizers (to reduce fading). Chemically resistant to blood, vinegar, urine, feces, salt solution, and chlorine solution.

Flammability Test Standards:

Certified to pass the following flammability standards:
 • State of California, Technical Bulletin No. 133, Flammability Test Procedure for Seating Furniture for Use in Public Occupancies.

Performance Test Standards:

• ANSI/BIFMA X5.1 2002 General Purpose Office Chairs.

Color:

Buff, Fog Grey, Plum, Teal, Slate Blue, Chestnut, Black.

Weight:

19.5 lbs.

Options:

Polyethylene ganging plates, polyethylene ballasting bags (requires clean, dry sand provided by end user or installer), stainless steel plates for bolt-down application.

Assembly:

None required.

Installation:

Required for bolt-down plates, ganging plates and ballast.

Warranty:

5 year limited replacement warranty.

Maintenance:

Easily cleaned with a damp cloth and a mild soap solution.

Filing System:

12600 Institutional Furniture
 11197 Correctional Furniture